



Description

Q-Tech's surface-mount QT93 and QT94 oscillators consist of a 5Vdc, 3.3Vdc, 2.5Vdc, 1.8Vdc CMOS or TTL output oscillator IC and a round AT high-precision quartz crystal built in a rugged surface-mount ceramic miniature package. It was designed to be replaceable and retrofitable into the footprint of a 5 x 7 mm COTS oscillator.

Features

- Made in the USA
- ECCN: EAR99
- DFARS 252-225-7014 Compliant: Electronic Component Exemption
- USML Registration # M17677
- Smallest AT round crystal package ever designed
- Broad frequency range from 15kHz to 162.5MHz
- Able to meet 36000G shock per ITOP 1-2-601
- Rugged 4 point mount design for high shock and vibration
- ACMOS, HCMOS, TTL, or LVHCMOS logic
- Tri-State Output
- Hermetically sealed ceramic SMD package
- Fundamental 3rd Overtone designs, no sub-harmonics
- Low phase noise, low noise coupling, low emissions
- Custom designs available
- Q-Tech does not use pure lead or pure tin in its products
- RoHS compliant



Applications

- Designed to meet today's requirements for low voltage applications
- Wide military clock applications
- Gun launched munitions and systems
- Smart munitions
- Navigation
- Industrial controls
- Microcontroller driver
- Down-hole applications up to +200°C
- SONET/SDH
- Fibre channel
- Gun launched munitions and systems
- Applications required high data transmission throughputs
- Clock generation and distribution
- Audio/Video signal processing
- Broadband access
- Ethernet, Gigabit Ethernet

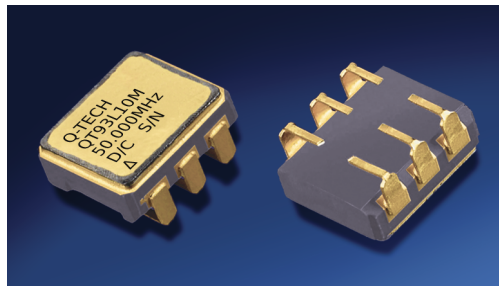

Ordering Information

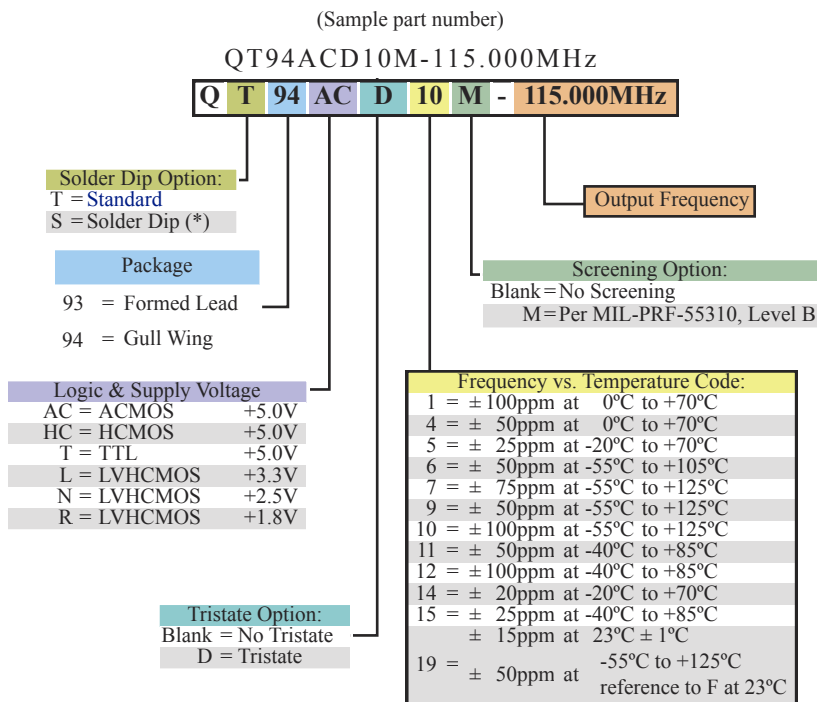

(*) Hot Solder Dip Sn60/Pb40 per MIL-PRF 55310 is optional for an additional cost

Frequency stability vs. temperature codes may not be available in all frequencies.

**For Non-Standard requirements,
contact Q-Tech Corporation at Sales@Q-Tech.com**

Packaging Options

- Standard packaging in anti-static plastic tube (60 pcs/tube)
- Tape and Reel (800 pcs/reel) is available for an additional charge.

Other Options Available For An Additional Charge

- P. I. N. D. test (MIL-STD 883, Method 2020)

Specifications subject to change without prior notice.



Package Outline and Pin Connections
Dimensions are in inches (mm)

QT93

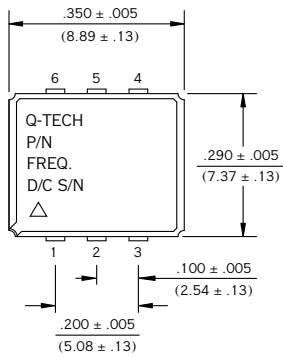

Pin No.	Function
1	TRISTATE or NC
2	NC
3	GND
4	OUTPUT
5	NC
6	VCC

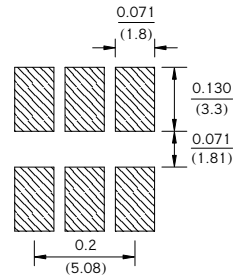
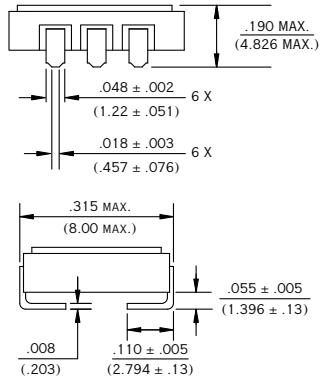

QT94

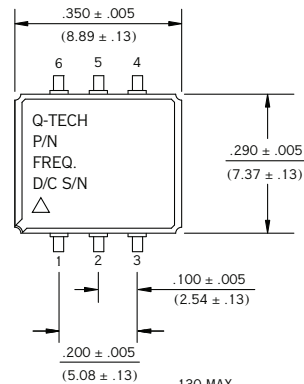

Pin No.	Function
1	TRISTATE or NC
2	NC
3	GND
4	OUTPUT
5	NC
6	VCC

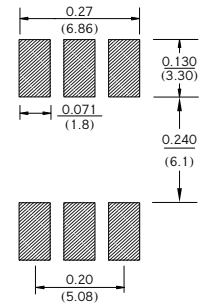
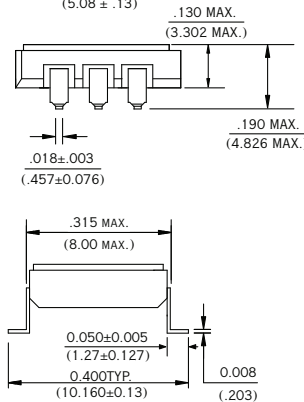

Package Information

- Package material: 91% AL₂O₃
- Lead material: Kovar
- Lead finish: Gold Plated: 50μ ~ 80μ inches
Nickel Underplate: 100μ ~ 250μ inches
- Weight: 0.6g typ., 3.0g max.

Electrical Characteristics

Parameters	AC	HC	T	L	N	R	
Output frequency range (Fo)	500kHz — 85.000MHz	15kHz — 85.000MHz(*)	500kHz — 85.000MHz	125kHz — 162.500MHz (*)	125.000kHz — 133.000MHz	125.000kHz — 100.000MHz	
Supply voltage (Vdd)	5.0Vdc ± 10%			3.3Vdc ± 10%		1.8Vdc ± 10%	
Maximum Applied Voltage (Vdd max.)	-0.5 to +7.0Vdc			-0.5 to +5.0Vdc			
Frequency stability (ΔF/ΔT)	See Option codes						
Operating temperature (Topr)	See Option codes						
Storage temperature (Tsto)	-62°C to + 125°C						
Operating supply current (Idd) (No Load)	20 mA max. - 15kHz ~ < 16MHz 25 mA max. - 16MHz ~ < 32MHz 35 mA max. - 32MHz ~ < 60MHz 45 mA max. - 60MHz ~ ≤ 85MHz			3 mA max. - 125kHz ~ < 500kHz 6 mA max. - 500kHz ~ < 16MHz 10 mA max. - 16MHz ~ < 32MHz 20 mA max. - 32MHz ~ < 60MHz 30 mA max. - 60MHz ~ < 100MHz 40 mA max. - 100MHz ~ < 130MHz 50 mA max. - 130MHz ~ ≤ 160MHz		3 mA max. - 125kHz ~ < 500kHz 6 mA max. - 500kHz ~ < 40MHz 15 mA max. - 40MHz ~ < 60MHz 25 mA max. - 60MHz ~ < 85MHz 35 mA max. - 85MHz ~ ≤ 133MHz	4 mA max. - 125kHz ~ < 40MHz 10 mA max. - 40MHz ~ < 50MHz 20 mA max. - 50MHz ~ < 85MHz 25 mA max. - 85MHz ~ ≤ 100MHz
Symmetry (50% of output waveform or 1.4Vdc for TTL)	45/55% max. - 15kHz ~ < 16MHz 40/60% max. - 16 ~ ≤ 85MHz (Tighter symmetry available)			45/55% max. - 125kHz ~ < 16MHz 40/60% max. - 16 ~ ≤ 160MHz (Tighter symmetry available)		45/55% max. - 125kHz ~ < 16MHz 40/60% max. - 16 ~ ≤ 133MHz (Tighter symmetry available)	45/55% max. - 125kHz ~ < 16MHz 40/60% max. - 16 ~ ≤ 100MHz (Tighter symmetry available)
Rise and Fall times (with typical load)	6ns max. - Fo < 30MHz 3ns max. - Fo ≥ 30 - 85MHz (between 10% to 90%)	6ns max. - Fo < 30MHz 3ns max. - Fo ≥ 30 - 85MHz (between 10% to 90%)	5ns max. - Fo < 30MHz 3ns max. - Fo ≥ 30 - 85MHz (between 0.8V to 2.0V)	6ns max. - 125kHz ~ < 40MHz 3ns max. - 40 ~ ≤ 160MHz (between 10% to 90%)	5ns max. - 125kHz ~ < 40MHz 3ns max. - 40 ~ ≤ 133MHz (between 10% to 90%)	5ns max. - 125kHz ~ < 40MHz 3ns max. - 40 ~ ≤ 100MHz (between 10% to 90%)	
Output Load	15pF // 10kohms 50pF max. or 10TTL for (Fo < 60MHz) 30pF max. or 6TTL for (Fo ≥ 60MHz)	15pF // 10kohms (2LSTTL)	10TTL (Fo < 60MHz) 6TTL (Fo ≥ 60MHz)	15pF // 10kohms (30pF max. for F ≤ 50MHz)	15pF // 10kohms		
Start-up time (Tstup)	5ms max.						
Output voltage (Voh/Vol)	0.9 x Vdd min.; 0.1 x Vdd max.		2.4V min.; 0.4V max.		0.9 x Vdd min.; 0.1 x Vdd max.		
Output Current (Ioh/Iol)	± 24mA max.	± 8mA max.	-1.6 mA/TTL +40 μA/TTL		± 4mA max.		
Enable/Disable Tristate function Pin 1	VIH ≥ 2.2V Oscillation; VIL ≤ 0.8V High Impedance				VIH ≥ 0.7 x Vdd Oscillation; VIL ≤ 0.3 x Vdd High Impedance		
Jitter RMS 1σ (at 25°C)	8ps typ. - < 40MHz 5ps typ. - ≥ 40MHz			15ps typ. - < 40MHz 8ps typ. - ≥ 40MHz			
Aging (at 70°C)	± 5ppm max. first year / ± 2ppm max. per year thereafter						

(*) Some frequencies lower than 500kHz may not be available with tristate function

Output Waveform (Typical)

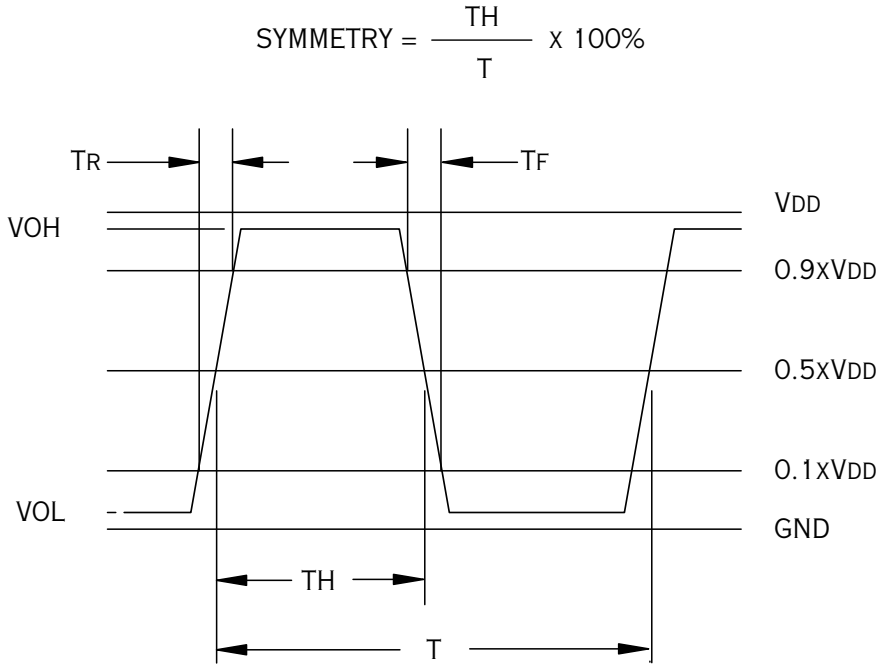

Test Circuit

TYPICAL TEST CIRCUIT FOR CMOS LOGIC

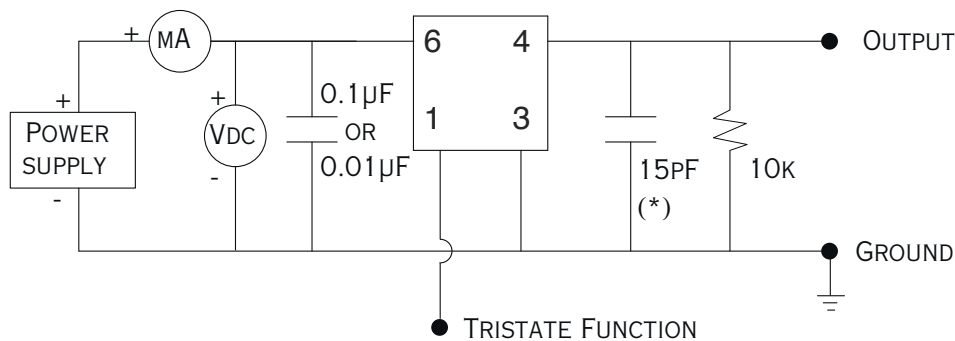

(*) CL INCLUDES PROBE AND JIG CAPACITANCE

The Tristate function on pin 1 has a built-in pull-up resistor so it can be left floating or tied to Vcc without deteriorating the electrical performance.

Reflow Profile

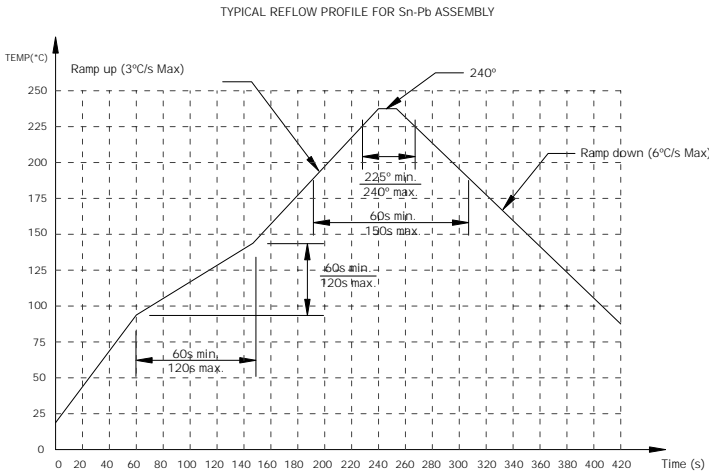

Embossed Tape and Reel Information

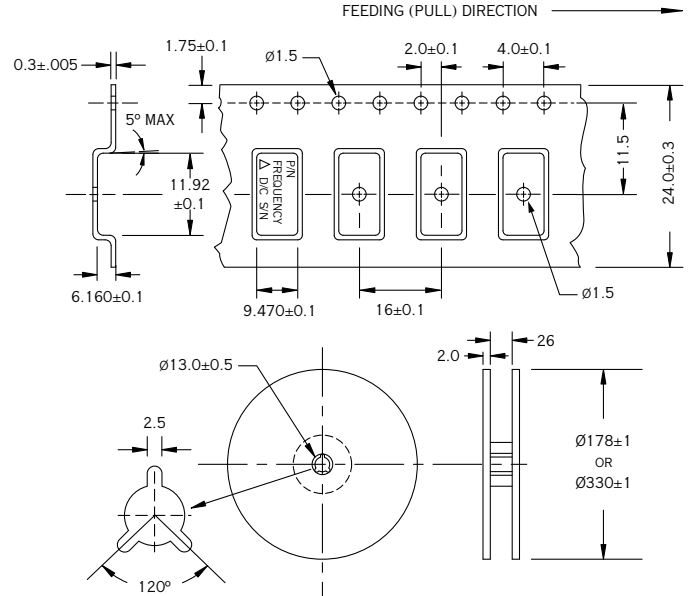

Reel size (Diameter in mm)	Qty per reel (pcs)
178	150
330	800

Environmental Specifications

Q-Tech Standard Screening/QCI (MIL-PRF55310) is available for all of our QT90 Products. Q-Tech can also customize screening and test procedures to meet your specific requirements. The QT90 product is designed and processed to exceed the following test conditions:

Environmental Test	Test Conditions
Temperature cycling	MIL-STD-883, Method 1010, Cond. B
Constant acceleration	MIL-STD-883, Method 2001, Cond. A, Y1
Seal: Fine and Gross Leak	MIL-STD-883, Method 1014, Cond. A and C
Burn-in	160 hours, 125°C with load
Aging	30 days, 70°C, ±1.5ppm max
Vibration sinusoidal	MIL-STD-202, Method 204, Cond. D
Shock, non operating	MIL-STD-202, Method 213, Cond. I (See Note 1)
Thermal shock, non operating	MIL-STD-202, Method 107, Cond. B
Ambient pressure, non operating	MIL-STD-202, 105, Cond. C, 5 minutes dwell time minimum
Resistance to solder heat	MIL-STD-202, Method 210, Cond. C
Moisture resistance	MIL-STD-202, Method 106
Terminal strength	MIL-STD-202, Method 211, Cond. C
Resistance to solvents	MIL-STD-202, Method 215
Solderability	MIL-STD-202, Method 208
ESD Classification	MIL-STD-883, Method 3015, Class 1 HBM 0 to 1,999V
Moisture Sensitivity Level	J-STD-020, MSL=1

Note 1: Additional shock results successfully passed on standard QT88 family 16MHz, 20MHz, 24MHz, 40MHz, and 80MHz

- Shock 850g peak, half-sine, 1 ms duration (MIL-STD-202, Method 213, Cond. D modified)
- Shock 1,500g peak, half-sine, 0.5ms duration (MIL-STD-883, Method 2002, Cond. B)
- Shock 36,000g peak, half-sine, 0.12 ms duration

Please contact Q-Tech for higher shock requirements

Phase Noise and Phase Jitter Integration

Phase noise is measured in the frequency domain, and is expressed as a ratio of signal power to noise power measured in a 1Hz bandwidth at an offset frequency from the carrier, e.g. 10Hz, 100Hz, 1kHz, 10kHz, 100kHz, etc. Phase noise measurement is made with an Agilent E5052A Signal Source Analyzer (SSA) with built-in outstanding low-noise DC power supply source. The DC source is floated from the ground and isolated from external noise to ensure accuracy and repeatability.

In order to determine the total noise power over a certain frequency range (bandwidth), the time domain must be analyzed in the frequency domain, and then reconstructed in the time domain into an rms value with the unwanted frequencies excluded. This may be done by converting $L(f)$ back to $S\phi(f)$ over the bandwidth of interest, integrating and performing some calculations.

The value of RMS jitter over the bandwidth of interest, e.g. 10kHz to 20MHz, 10Hz to 20MHz, represents 1 standard deviation of phase jitter contributed by the noise in that defined bandwidth.

Figure 1 shows a typical Phase Noise/Phase jitter of a QT94L, 3.3Vdc, 20MHz clock at offset frequencies 10Hz to 1MHz, and phase jitter integrated over the bandwidth of 12kHz to 1MHz.

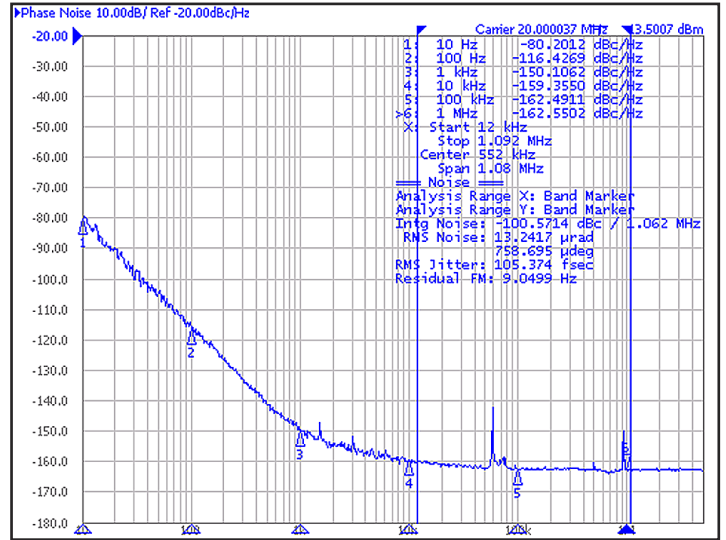

(Figure 1)

Thermal Characteristics

The heat transfer model in a hybrid package is described in figure 2.

Heat spreading occurs when heat flows into a material layer of increased cross-sectional area. It is adequate to assume that spreading occurs at a 45° angle.

The total thermal resistance is calculated by summing the thermal resistances of each material in the thermal path between the device and hybrid case.

$$RT = R1 + R2 + R3 + R4 + R5$$

The total thermal resistance RT (see figure 2) between the heat source (die) to the hybrid case is the Theta Junction to Case (θ_{JC}) in °C/W.

- Theta junction to case (θ_{JC}) for this product is 30°C/W.
- Theta case to ambient (θ_{CA}) for this part is 100°C/W.
- Theta Junction to ambient (θ_{JA}) is 130°C/W.

Maximum power dissipation PD for this package at 25°C is:

- $PD(max) = (T_J(max) - T_A) / \theta_{JA}$
- With $T_J = 175^\circ\text{C}$ (Maximum junction temperature of die)
- $PD(max) = (175 - 25) / 130 = 1.15\text{W}$

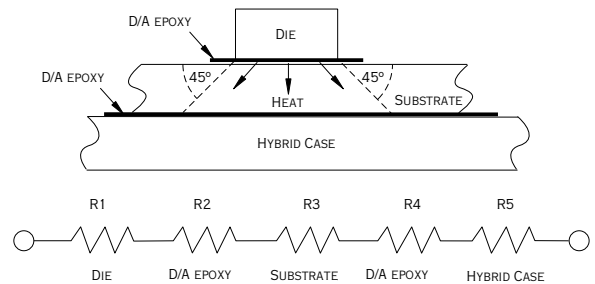

(Figure 2)

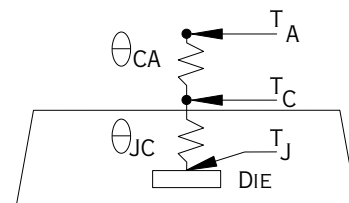

$$\theta_{JA} = \theta_{JC} + \theta_{CA}$$

(Figure 3)



DCO	REV	REVISION SUMMARY	PAGE	DATE
6421	A	Add frequency code 19	4	2/8/17
6492	B	Add frequency code 7	4	3/6/17
		Removed LVDS and LVPECL options (See QPDS-0095 -- QT94W and QT94P Series Data Sheet for these options)	All	
6651	C	Remove radiation tolerance limit in features and benign space environments in applications.	1	4/6/17
		Change max frequency from 320MHz to 162.5MHz	All	
9709	D	Fix recommended land pattern. Previous land pattern was for QT93	1	4/10/19
15793	E	Add QT93 package to data sheet	All	9/01/22
		Move ordering information to page 1	1	
		Move package outlines to page 2	2	