

Description

Q-Tech's surface-mount QT89 oscillators consist of an IC 5Vdc, 3.3Vdc, 2.5Vdc, 1.8Vdc clock square wave generator and a high-precision quartz crystal built in a rugged leaded miniature package. This package is primarily designed for down-hole applications with 5Vdc or 3.3Vdc supply voltage.

Features

- Made in the USA
- ECCN: EAR99
- DFARS 252-225-7014 Compliant: Electronic Component Exemption
- USML Registration # M17677

- Able to meet 36000G shock per ITOP 1-2-601
- Broad frequency range from 15kHz to 160MHz (frequency to 1kHz available without Tristate function)
- Rugged design for high shock and vibration
- Leaded parts suitable for high temperature and shock applications
- Thru-hole mounting on PCB provides strong mechanical bonds compared to SMT techniques
- ACMOS, HCMOS, TTL or LVHCMOS logic
- Tri-State Output Option (D)
- Hermetically sealed ceramic SMD package
- Fundamental and 3rd Overtone designs
- Low phase noise
- Custom designs available
- Q-Tech does not use pure lead or pure tin in its products
- RoHS compliant



Applications

- Designed to meet today's requirements for low voltage applications
- Down-hole oil wells
- Industrial process control
- Wide military clock applications
- Gun launched munitions and systems
- Benign space environments
- Smart munitions
- Navigation
- Avionics
- Microcontroller driver

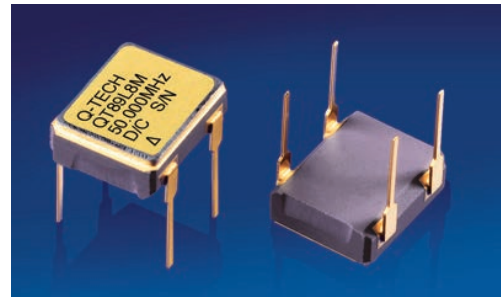

Package Outline and Pin Connections

Dimensions are in inches (mm)

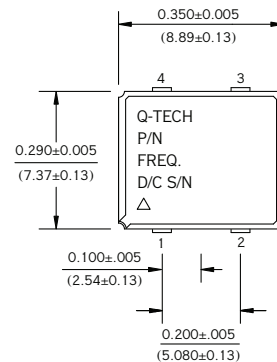

Pin No.	Function
1	TRISTATE or NC
2	GND/CASE
3	OUTPUT
4	VDD

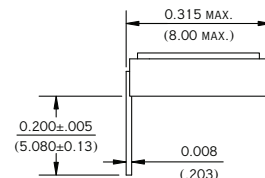
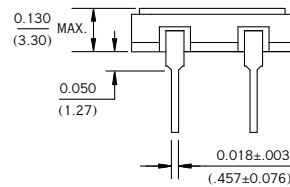

Package Information

- Package material: 91% AL₂O₃
- Lead material: Kovar
- Lead finish: Gold Plated: 50μ ~ 80μ inches
 Nickel Underplate: 100μ ~ 250μ inches
- Weight: 0.6g typ., 3.0g max.



Electrical Characteristics

Parameters	QT89AC	QT89HC	QT89T	QT89L	QT89N	QT89R
Output frequency range (Fo)	500kHz — 85.000MHz	15kHz — 85.000MHz(*)	500kHz — 85.000MHz	15kHz — 160.000MHz (*)	125.000kHz — 133.000MHz	125.000kHz — 100.000MHz
Supply voltage (Vdd)	5.0Vdc ± 10%			3.3Vdc ± 10%		1.8Vdc ± 10%
Maximum Applied Voltage (Vdd max.)	-0.5 to +7.0Vdc			-0.5 to +5.0Vdc		
Frequency stability (ΔF/ΔT)	See Option codes					
Operating temperature (Topr)	See Option codes					
Storage temperature (Tsto)	-62°C to + 125°C					
Operating supply current (Idd) (No Load)	20 mA max. - 15kHz ~ < 16MHz 25 mA max. - 16MHz ~ < 32MHz 35 mA max. - 32MHz ~ < 60MHz 45 mA max. - 60MHz ~ ≤ 85MHz			3 mA max. - 15kHz ~ < 500kHz 6 mA max. - 500kHz ~ < 16MHz 10 mA max. - 16MHz ~ < 32MHz 20 mA max. - 32MHz ~ < 60MHz 30 mA max. - 60MHz ~ < 100MHz 40 mA max. - 100MHz ~ < 130MHz 50 mA max. - 130MHz ~ ≤ 160MHz		4 mA max. - 125kHz ~ < 40MHz 10 mA max. - 40MHz ~ < 50MHz 20 mA max. - 50MHz ~ < 85MHz 25 mA max. - 85MHz ~ ≤ 100MHz
Symmetry (50% of output waveform or 1.4Vdc for TTL)	45/55% max. - 15kHz ~ < 15MHz 40/60% max. - 15MHz ~ ≤ 85MHz (Tighter symmetry available)			45/55% max. - 15kHz ~ < 15MHz 40/60% max. - 15MHz ~ ≤ 160MHz (Tighter symmetry available)		45/55% max. - 125kHz ~ < 15MHz 40/60% max. - 15MHz ~ ≤ 133MHz (Tighter symmetry available)
Rise and Fall times (with typical load)	200ns max. Fo ≤ 345.6kHz 8ns max. Fo 345.6kHz ~ ≤ 20MHz 5ns max. Fo 20MHz ~ ≤ 50MHz 7ns max. - 20MHz ~ ≤ 50MHz (50pF Load) 3ns max. Fo > 50MHz (Measured from 10% to 90% CMOS or from 0.8V to 2.0V TTL)			200ns max. Fo ≤ 345.6kHz 6ns max. Fo 345.6kHz ~ ≤ 20MHz 4ns max. Fo 20MHz ~ ≤ 50MHz 3ns max. Fo > 50MHz 7ns max. - 50pF Load (Measured from 10% to 90%)		
Output Load	15pF // 10kohms 50pF max. or 10TTL for (Fo < 40MHz) 30pF max. or 6TTL for (Fo ≥ 40MHz)	15pF // 10kohms (2LSTTL)	10TTL (Fo < 60MHz) 6TTL (Fo ≥ 60MHz)	15pF // 10kohms (30pF max. available for F ≤ 40MHz)	15pF // 10kohms	
Start-up time (Tstup)	10ms max.				5ms max.	
Output voltage (Voh/Vol)	0.9 x Vdd min.; 0.1 x Vdd max.		2.4V min.; 0.4V max.		0.9 x Vdd min.; 0.1 x Vdd max.	
Output Current (Ioh/Iol)	± 24mA max.	± 16mA max.	-1.6 mA/TTL +40 μA/TTL	± 8mA max.		
Enable/Disable Tristate function Pin 1	VIH ≥ 4.0V Oscillation; VIL ≤ 0.8V High Impedance		VIH ≥ 2.2V Oscillation; VIL ≤ 0.8V High Impedance		VIH ≥ 2.0V Oscillation; VIL ≤ 0.5V High Impedance	
Jitter RMS 1σ (at 25°C)	8ps typ. - < 40MHz 5ps typ. - ≥ 40MHz			15ps typ. - < 40MHz 8ps typ. - ≥ 40MHz		
Aging (at 70°C)	± 5ppm max. first year / ± 2ppm max. per year thereafter					

(*) Some frequencies lower than 500kHz may not be available with tristate function. Frequencies as low as 1kHz are available.

Ordering Information

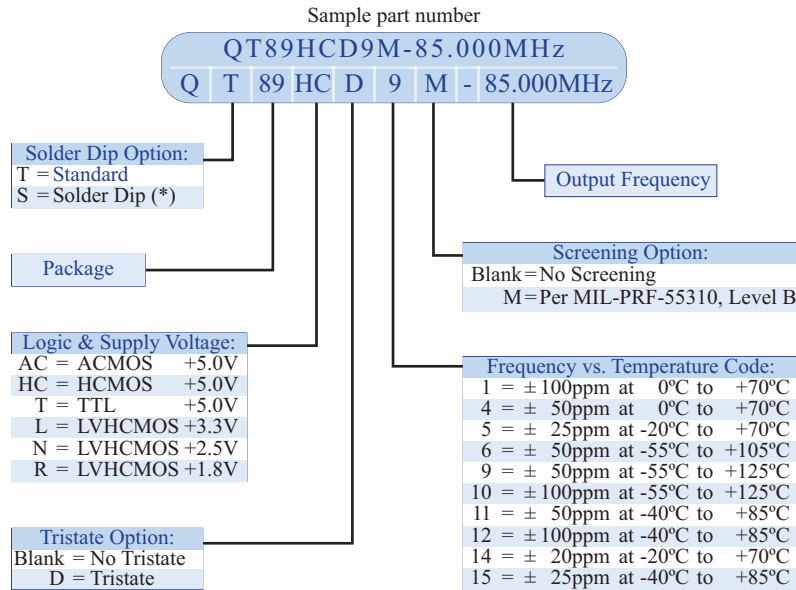

(*) Hot Solder Dip Sn60/Pb40 per MIL-PRF 55310 is optional for an additional cost

Frequency stability vs. temperature codes may not be available in all frequencies.

**For Non-Standard requirements,
contact Q-Tech Corporation at Sales@Q-Tech.com**

Packaging Options

- Standard packaging in anti-static plastic tube (60 pcs/tube)

Other Options Available For An Additional Charge

- P. I. N. D. test (MIL-STD 883, Method 2020)

Specifications subject to change without prior notice.

Reflow and Soldering Techniques

Unless otherwise specified, soldering should be performed on terminals at 260°C for 10s maximum. Do not apply soldering heat on oscillator package since it could damage the unit. Hand soldering is recommended. Wave solder at 245°C for 15s max.

Thermal Characteristics

The heat transfer model in a hybrid package is described in figure 1.

Heat spreading occurs when heat flows into a material layer of increased cross-sectional area. It is adequate to assume that spreading occurs at a 45° angle.

The total thermal resistance is calculated by summing the thermal resistances of each material in the thermal path between the device and hybrid case.

$$RT = R1 + R2 + R3 + R4 + R5$$

The total thermal resistance RT (see figure 2) between the heat source (die) to the hybrid case is the Theta Junction to Case (Theta JC) in °C/W.

- Theta junction to case (Theta JC) for this product is 30°C/W.
- Theta case to ambient (Theta CA) for this part is 100°C/W.
- Theta Junction to ambient (Theta JA) is 130°C/W.

Maximum power dissipation PD for this package at 25°C is:

- $PD(max) = (TJ(max) - TA)/\theta_{JA}$
- With $TJ = 175^\circ C$ (Maximum junction temperature of die)
- $PD(max) = (175 - 25)/130 = 1.15W$

Environmental Specifications

Q-Tech Standard Screening/QCI (MIL-PRF55310) is available for all of our QT89 Products. Q-Tech can also customize screening and test procedures to meet your specific requirements. The QT89 product is designed and processed to exceed the following test conditions:

Environmental Test	Test Conditions
Temperature cycling	MIL-STD-883, Method 1010, Cond. B
Constant acceleration	MIL-STD-883, Method 2001, Cond. A, Y1
Seal: Fine and Gross Leak	MIL-STD-883, Method 1014, Cond. A and C
Burn-in	160 hours, 125°C with load
Aging	30 days, 70°C, ±1.5ppm max
Vibration sinusoidal	MIL-STD-202, Method 204, Cond. D
Shock, non operating	MIL-STD-202, Method 213, Cond. I (See Note 1)
Thermal shock, non operating	MIL-STD-202, Method 107, Cond. B
Ambient pressure, non operating	MIL-STD-202, 105, Cond. C, 5 minutes dwell time minimum
Resistance to solder heat	MIL-STD-202, Method 210, Cond. C
Moisture resistance	MIL-STD-202, Method 106
Terminal strength	MIL-STD-202, Method 211, Cond. C
Resistance to solvents	MIL-STD-202, Method 215
Solderability	MIL-STD-202, Method 208
ESD Classification	MIL-STD-883, Method 3015, Class 1 HBM 0 to 1,999V
Moisture Sensitivity Level	J-STD-020, MSL=1

Note 1: Additional shock results successfully passed on standard QT88 family 16MHz, 20MHz, 24MHz, 40MHz, and 80MHz

- Shock 850g peak, half-sine, 1 ms duration (MIL-STD-202, Method 213, Cond. D modified)
- Shock 1,500g peak, half-sine, 0.5ms duration (MIL-STD-883, Method 2002, Cond. B)
- Shock 36,000g peak, half-sine, 0.12 ms duration

Please contact Q-Tech for higher shock requirements

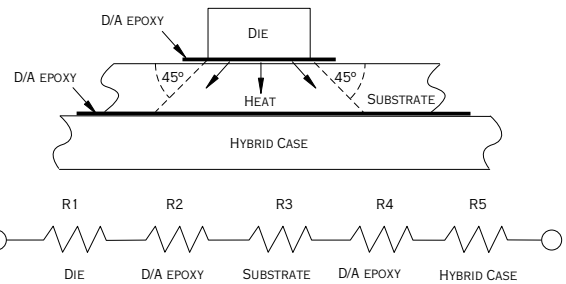

(Figure 1)

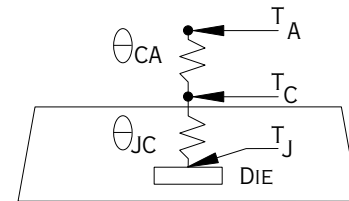

$$\theta_{JA} = \theta_{JC} + \theta_{CA}$$

(Figure 2)

Output Waveform (Typical)

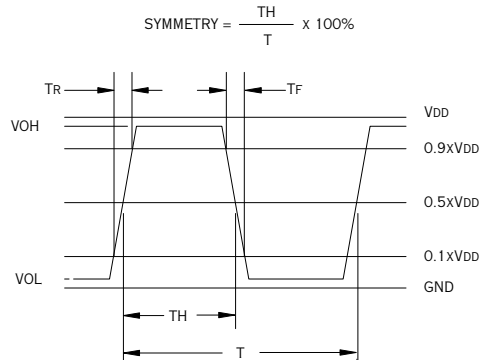

Test Circuit

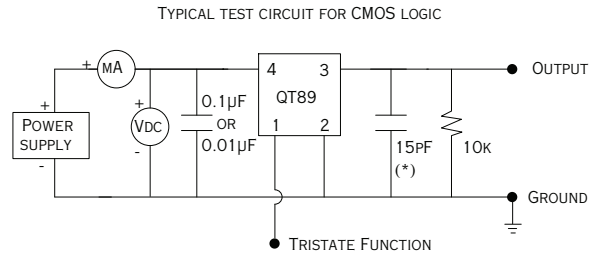

(* CL INCLUDES PROBE AND JIG CAPACITANCE

The Tristate function on pin 1 has a built-in pull-up resistor typical 50kΩ, so it can be left floating or tied to Vdd without deteriorating the electrical performance.

Frequency vs. Temperature Curve

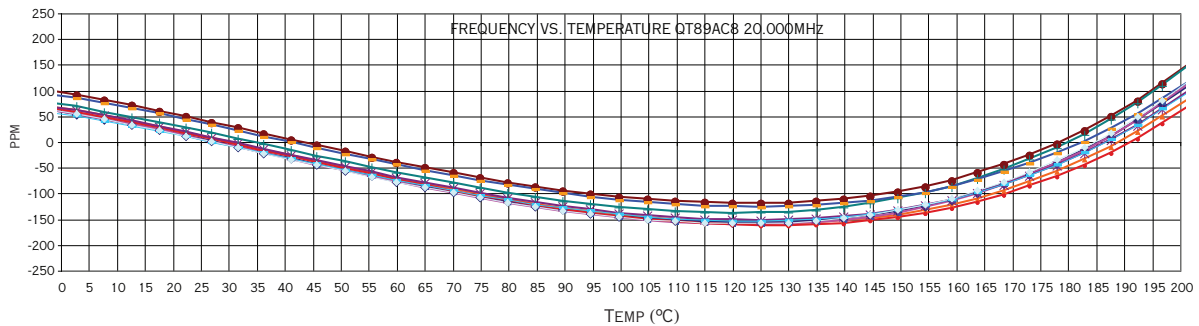

TYPICAL SUPPLY CURRENT ICC (MA) AT 3.3Vdc & 5.0Vdc NO LOAD

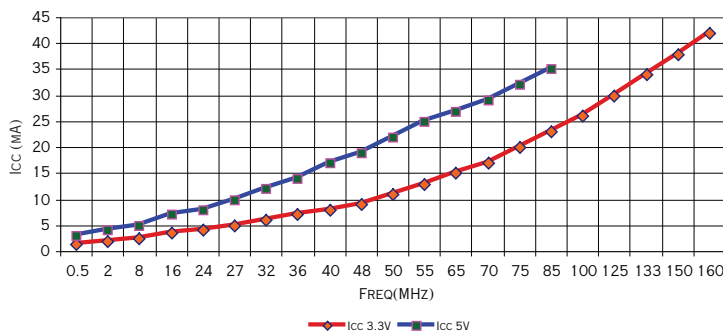

Typical start-up time of a QT89HC8M-20.000MHz 5.0Vdc at +200°C (~1.75ms)

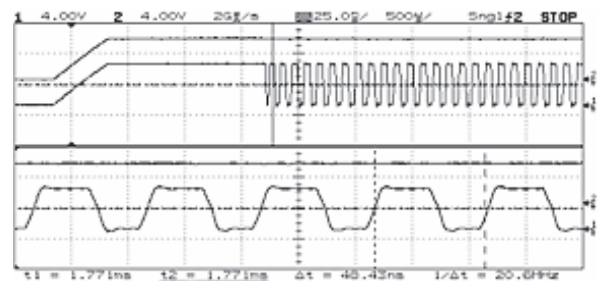

Period Jitter

As data rates increase, effects of jitter become critical with its budgets tighter. Jitter is the deviation of a timing event of a signal from its ideal position. Jitter is complex and is composed of both random and deterministic jitter components. Random jitter (RJ) is theoretically unbounded and Gaussian in distribution. Deterministic jitter (DJ) is bounded and does not follow any predictable distribution. DJ is also referred to as systematic jitter. A technique to measure period jitter (RMS) one standard deviation (1σ) and peak-to-peak jitter in time domain is to use a high sampling rate (>8G samples/s) digitizing oscilloscope. Figure shows an example of peak-to-peak jitter and RMS jitter (1σ) of a QT89L-24MHz, at 3.3Vdc.

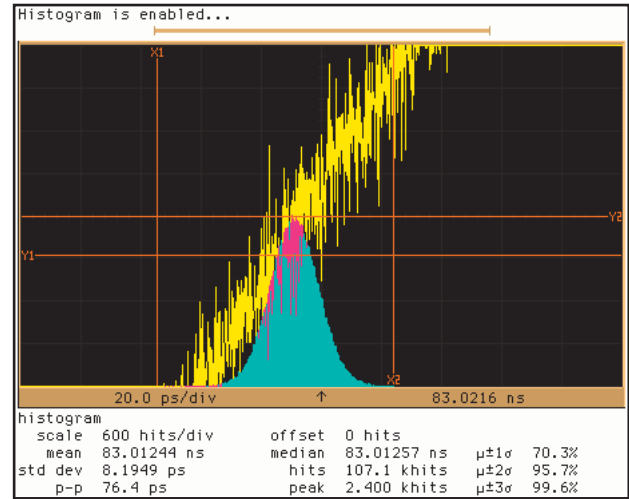

RMS jitter (1σ): 8.19ps Peak-to-peak jitter: 76ps

Phase Noise and Phase Jitter Integration

Phase noise is measured in the frequency domain, and is expressed as a ratio of signal power to noise power measured in a 1Hz bandwidth at an offset frequency from the carrier, e.g. 10Hz, 100Hz, 1kHz, 10kHz, 100kHz, etc. Phase noise measurement is made with an Agilent E5052A Signal Source Analyzer (SSA) with built-in outstanding low-noise DC power supply source. The DC source is floated from the ground and isolated from external noise to ensure accuracy and repeatability.

In order to determine the total noise power over a certain frequency range (bandwidth), the time domain must be analyzed in the frequency domain, and then reconstructed in the time domain into an rms value with the unwanted frequencies excluded. This may be done by converting $L(f)$ back to $S\phi(f)$ over the bandwidth of interest, integrating and performing some calculations.

Symbol	Definition
$\int L(f)$	Integrated single side band phase noise (dBc)
$S\phi(f) = (180/\pi) \times \sqrt{2} \int L(f) df$	Spectral density of phase modulation, also known as RMS phase error (in degrees)
RMS jitter = $S\phi(f) / (f_{osc} \cdot 360^\circ)$	Jitter (in seconds) due to phase noise. Note $S\phi(f)$ in degrees.

The value of RMS jitter over the bandwidth of interest, e.g. 10kHz to 20MHz, 10Hz to 20MHz, represents 1 standard deviation of phase jitter contributed by the noise in that defined bandwidth.

Figure below shows a typical Phase Noise/Phase jitter of a QT89L, 3.3Vdc, 50MHz clock at offset frequencies 10Hz to 5MHz, and phase jitter integrated over the bandwidth of 12kHz to 1MHz.

